

Design of Power System Stabilizer with PSO for Heffron-Phillip's Model

H. Aliyari¹
R. Effatnejad²
H. Tadayyoni³
A. Aryaei¹

Abstract

Power systems are one of the hugest dynamic systems and power engineers have always focused on the problem of their stability. The beginning of studies on this problem (system stability) belongs to the first years of the 1920s. After that there always have been wide researches on studying the phenomena that make the systems unstable and threaten the power system stabilizers. The small signal stability is one of the related topics to the problem of power system stability and it is gained by developing and connecting power systems together. This problem, also, has drawn the power engineers' attention. The previous studies have led to some procedures for improving the power system stability. PSS [1] is one of the developments on this problem. Also, using optimum control and smart control procedures has been under attention recently. This paper has focused on the classic PSS in the system stability under small turbulence and better attenuation. After that a study on finding PSS coefficients using the smart PSO [2] algorithm have been done along with observing the point that using this algorithm leads to better results and that this procedure has made better results for sure.

Index Terms: power system stability, PSS, PSO.

1. Introduction

The power system stability problems are divided into two categories: the angle stability and the voltage stability. The angle stability is related to preserving the synchronism of the synchronous machine in the network, after observing system turbulence. The angle stability itself includes the small signal stability (in small turbulences) and the transient stability (in huge turbulences). When using the small signal stability, we mean the system ability to damp the low frequency fluctuations [3] (the mechanical mode of the system) after some small alterations in the system. If the system is not able to damp this kind of fluctuations, they remain in the system and can make the system unstable. Until the beginning of the 1960s, the system stability studies were only focused on the transient stability.

¹ Electrical Engineering Department , Science And Reaserch Alborz branch, Islamic Azad University, Alborz , Iran.

² Electrical Engineering Department , Karaj branch, Islamic Azad University, Alborz , Iran.

³ Electrical and Computer Engineering Department, Tehran University, Tehran, Iran.

Yet, after power system developments and their connections, and the rotor low frequency fluctuations [4] that occurred after low amplitude turbulences phenomena in the network, the study of small signal stability has been started in the power system stability issue.

Although fast stimulation systems [5] improve the transient stability, but they make negative attenuation and small signal instability in the system by themselves. Finding a good solution for using the ability of the stimulation systems to improve the transient stability and make small signal instability led to introducing the PSS. Also, the developments which occurred in the control theory and introducing lots of new control methods, led to the point that the optimum control and kinds of fussy methods[6] are being used in the small signal stability problem. The introduction of the FACTS [7] equipment (like SSSC and STATCOM [8]), also led to some improvements in the power system stability in the two categories of the transient stability and the small signal stability.

2. Power System Modeling In Studying the Small Signal Stability

As it was mentioned above, the small signal studies focus on the system stability towards small fluctuations, so in this zone, the change range of the system about the task point is small and the chance to linearize the system is available. In lots of researches about the small signal stability, the linearized model of the infinite machine-bus is being used (Figure 1). For modeling the machine, the 3rd degree model of the machine [9], [10] is used (not including the damper coils, the stator resistances and stator coils dynamics). Using this model in the stability studies seems so logical. Not including the damper coils and the stator resistances leads to a kind of conservatism in designing the stabilizer. Also, not including the stator's dynamics (fast electrical modes) does not have any effect on studying the stability.

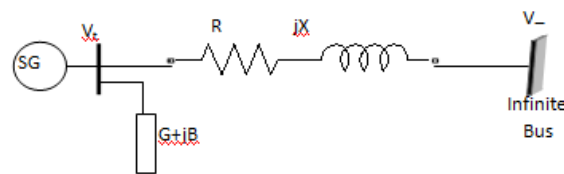

Figure 1: The Infinite Machine- bus Model

The 3rd degree equations for the machine are as below:

$$v_{qs} = \psi_{ds} \xrightarrow{\psi_{ds} = E'_q - X'_d i_{ds}} v_{qs} = E'_q - X'_d i_{ds} \quad (1)$$

$$v_{ds} = -\psi_{qs} \xrightarrow{\psi_{qs} = -X_q i_{qs}} v_{ds} = X_q i_{qs} \quad (2)$$

$$E'_{FD} = E'_q + (X_d - X'_d) i_{ds} + \frac{X'_{fd}}{\omega_b r'_{fd}} p E'_q \quad (3)$$

$$T_m - T_e = \frac{2H}{\omega_b} \frac{d\omega}{dt} \quad (4)$$

Where X'_d is the transient reactance of the d axis and E'_q is the open circuit voltage in the transient mode.

The machine equations in the linear mode are as below:

$$\Delta v_{qs} = \Delta E'_q - X'_d \Delta i_{ds} \quad (5)$$

$$\Delta v_{ds} = X_q \Delta i_{qs} \quad (6)$$

$$E'_{FD} = \Delta E'_q + (X_d - X'_d) \Delta i_{ds} + \frac{X'_{fd}}{\omega_b r'_{fd}} p \Delta E'_q \quad (7)$$

To obtain a proper model, the network equations should be written in the coordinate system of the rotor along with the machine equations and they also have to be linearized. So assuming that the d axis is the reference axis, then the relationship between the “a” phase phasor and the components on the d and q axis are written as below:

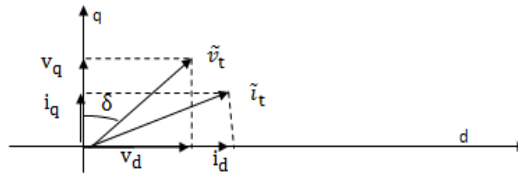

Figure 2: The relationship between the phasor and the q and d parameters

$$\tilde{v}_t = v_d + jv_q \quad (8)$$

$$\tilde{i}_t = i_d + ji_q \quad (9)$$

$$\tilde{i}_t = \tilde{v}_t (G + jB) + \frac{\tilde{v}_t - \tilde{v}_\infty}{R + jX} \quad (10)$$

If the q and d parameters are inserted in to the phasor equations:

$$\tilde{i}_t = i_d + ji_q = \frac{(v_d + jv_q)(G + jB) + v_d + jv_q - v_\infty \sin \delta - jv_\infty \cos \delta}{R + jX} \quad (11)$$

By linearizing the above equation and inserting the v_d and v_q by their values on the basis of i_q, i_d, E'_q and X'_d , the relationship between Δi_{ds} and Δi_{qs} is obtained in the basis of $\Delta E'_q$ and $\Delta \delta$, and the following equations are prepared:

$$\Delta T_e = K_1 \Delta \delta + K_2 \Delta E'_q \quad (12)$$

$$\Delta v_t = K_5 \Delta \delta + K_6 \Delta E'_q \quad (13)$$

$$\Delta E'_q = (-K_4 \Delta \delta + \Delta e'_{XFD}) \frac{K_3}{1 + \tau'_{d0} K_3} \quad (14)$$

The coefficients K_1 to K_6 are related to the machine parameters and the primary work state of the machine. To calculate the values of K_1 to K_6 , the torque, terminal voltage and the stimulation coil equations should be linearized. And by eliminating the Δi_{ds} and the Δi_{qs} and rewriting the equations on the basis of $\Delta E'_q$ and $\Delta \delta$, the coefficients are calculated. The systematic approach to calculate the coefficients is mentioned in the reference [11]. The linearized 3rd degree model of the machine will be represented as in figure 3.

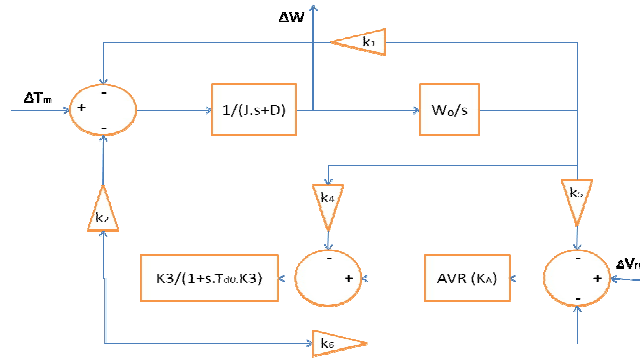

Figure 3: The linearized 3rd degree model of the machine

Pay attention that the stimulation system is modeled here as a 1st degree system. The non-linear behavior is only because of the under stimulation limitation (UEL4), the over stimulation limitation (OEL5) and the V/HZ6 limitation, that are inserted into the stimulation model, as some limiters. Yet, because the goal is the small signal analysis of the system, then the effect of the limiter can be ignored and the stimulation can be modeled as a linear system.

The above model is used in many of small signal studies. Pay attention that if the system does not owe a stimulation, then the AVR transfer function and the K_5 and K_6 would be eliminated from the above block diagram.

3. Formulating the Problem

Figure 3 below shows the system that has been studied: a single machine infinite bus system . The infinite bus represents the Thevenin equivalent circuit of the huge network that is connected to the system.

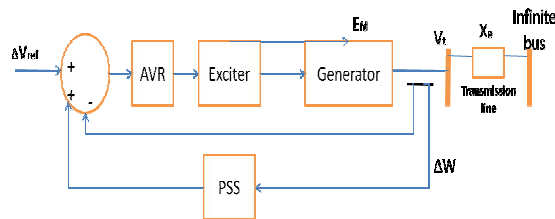

Figure 4: The single machine system connected to the infinite bus

¹Under excitation limit

²Over excitation limit

³ Volt per Hertz limit

The non- linear equations are as below:

$$\dot{\omega} = \frac{T_m - T_e}{M} \quad (14)$$

$$\dot{E}'_q = \frac{1}{T'_{d0}} \left(E_{fd} - \frac{x_d + x_e}{x'_d + x_e} E'_q + \frac{x_d + x'_d}{x'_d + x_e} V \cos \delta \right) \quad (15)$$

$$E_{fd} = \frac{1}{T_E} (K_E E_{ref} - K_E V_t - E_{fd}) \quad (16)$$

$$\dot{\delta} = \omega_0 \omega \quad (17)$$

The above equations can be linearized about the work point for small fluctuations.

The model parameters are a function of the load (P,Q). The system state equation is given as below:

$$\dot{x} = Ax + Bu \quad (18)$$

$$y = Cx \quad (19)$$

Where:

$$x = [\Delta\delta \Delta\omega \Delta E'_q \Delta E_{fd}] \quad (20)$$

$$A = \begin{bmatrix} 0 & \omega_0 & 0 & 0 \\ -\frac{k_1}{M} & 0 & -\frac{k_2}{M} & 0 \\ \frac{k_4}{T'_{d0}} & 0 & -\frac{1}{T} - \frac{1}{T'_{d0}} & 1 \\ -\frac{k_5 k_E}{T_E} & 0 & -\frac{k_6 k_E}{T_E} - \frac{1}{T_E} & 1 \end{bmatrix}, \quad B = \begin{bmatrix} 0 \\ 0 \\ 0 \\ \frac{k_E}{T_E} \end{bmatrix}, \quad (21)$$

$$C = [0 \quad 1 \quad 0 \quad 0], \quad T = k_3 T'_{d0} \quad (22)$$

The constant values of K_1 to K_6 are the system parameters under the specific operation mode. The sample values for this kind of system are as below:

MACHINE PARAMETERS	LINE PARAMETERS
$X_d = 0.973pu$	$B=0.262pu$
$\tau'_{d0} = 7.76(sec)$	$G=0.249pu$
$D=0$	$X=0.997pu$
$2H=9.26(sec)$	$R=0$
$X_q = 0.55pu$	INITIAL
$X_d = 0.973pu$	CONDITIONS
$X'_d = 0.19pu$	$v_{to} = 1.05$
AVR PARAMETERS	$Q_e = 0.015pu$
$K_A=50$	$P_e = 1pu$

Table 1: The sample values for this kind of system

It will be mentioned that for calculating these coefficients, the values of I_q , I_d , V_q , V_d and V_{ω} are to be calculated first.

$v_{d0} = 0.4659pu$	$v_{q0} = 0.941pu$	$i_{q0} = 0.8471pu$
$i_{d0} = 0.4354pu$	$E'_{q0} = 1.0237pu$	

Table 2: The values of the primary voltages and the primary currents of the system

$K_1=0.5473$	$K_1=1.2332$	$K_3=0.6565$
$K_4=0.6801$	$K_1=-0.0895$	$K_1=0.8201$

Table 3: The values calculated for K_1 to K_6 in the studied problem

The state matrixes would be as below:

$$A = \begin{bmatrix} 0 & 377 & 0 & 0 \\ -0.0591 & 0 & 0 & -0.1332 \\ 089.4988 & 0 & -20 & -820.0923 \\ -0.0876 & 0 & 0.1289 & -0.1963 \end{bmatrix} \quad (23)$$

The characteristic values of the system:

$0.2805 \mp j4.96$
$-10.3786 \mp j3.3374$

Table 4: The characteristic values of the system

4. Introducing the PSS

The AVR view of the system usually increases the value of synchronous torque, but gives negative attenuation to the system. PSS or the Power System Stabilizer increase the damping torque, but does not affect the synchronous torque so much and so it is suitable for the small signal analysis mode. The target of the PSS is increasing the attenuation, so an aligned component to the velocity should be added to the electromagnetic torque ($\Delta T_e = K_1 \Delta \delta + K_2 \Delta E'_q$). This is possible by adding a component to the ΔE , aligned to the velocity. To make this kind of signal, a signal can be used to represent the changes in the velocity, as the input. The best signal for this purpose can be the $\Delta \omega$, which is proper for measurement too, yet, using signals like Δf and ΔP_d (the accelerator's power) is also usual. This input signal can be used as the input of the AVR system. According to the figure 3-1, it can be seen that using the $\Delta \omega$ directly as the input of the AVR makes a phase shifted signal (to the amount of AVR phase and stimulation coil) $\Delta E'_q$, so before utilizing the $\Delta \omega$, a feigned lead should be made. This is possible by using a lead controller. Also, controlling the amount of damping is available by using a regulation coefficient controller. At last, the controller is as shown in the below figure:

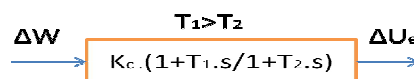

Figure 5: the lead controller

Where ΔU_E is the input signal to the regulator.

Also to make the PSS system to be available only in the times of need and the transient state and that in the Static work state, it does not interfere the voltage regulator task (The machine terminal voltage regulation), the WASHOUT system is used. To make this system not to change the phase in the system, the big T circuit is used.

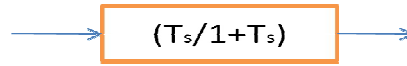

Figure 6: the WASHOUT System

4.1. How to use the PSS in the system

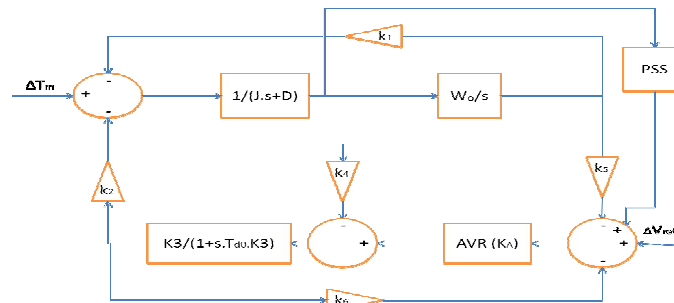

Figure 5: linearized 3rd degree model of the machine with PSS

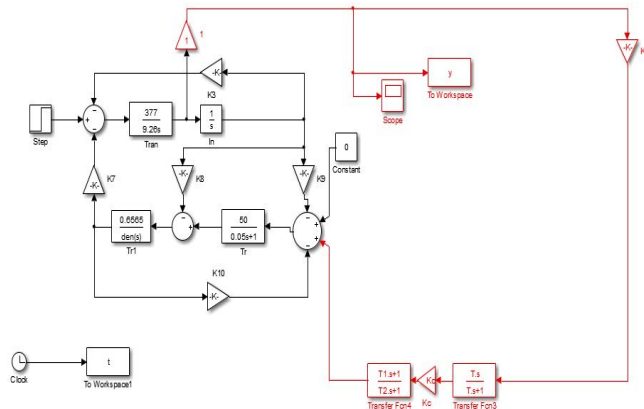

Figure 6: linearized 3rd degree model of the machine with PSS in Matlab

4.2. Determining the preferred lead

The input signal of the PSS is entered through the stimulation system. This signal includes the amount of the lag due to the stimulation coil and the AVR, from the time that it is to the system up to the time that it affects the field ($\Delta E'_q$) and so the electromagnetic torque. This lag should be avoided. According to the figure 7-1, it can be written:

$$G_E(s) = \frac{\Delta E'_q}{u_E} = \frac{K_3 K_a}{K_3 T'_{do} T_a s^2 + (K_3 T'_{do} + T_a) s + 1 + K_3 K_6 K_a} = \frac{32.825}{0.2547s^2 + s(5.1448) + 27.9197}$$

Assuming $T_2 = 0.08$, then:
 $\angle G_c(4.72j) = \tan^{-1} 4.72T_1 - \tan^{-1}(4.72 * 0.08) = 47.51$
 $T_1 = 0.5296$

The gain of the controller can be calculated according to the preferred amount of damping. If $\xi = 0.3$ is preferred, then according to figure 7-1:

$$\Delta T_e|_{PSS} = K_2 \Delta E'_q|_{PSS} = K_2 G_c(s) G_E(s) \Delta \omega$$

$$D_{PSS} = K_2 |G_c(4.72j)| |G_E(4.72j)|$$

It is known that there is no attenuation in the system, so all amount of the attenuation is because of the PSS. According to the equation:

$$\Delta T_m = \frac{2H}{\omega_b} \frac{d^2 \delta}{dt^2} + \frac{D_{PSS}}{\omega_b} \frac{d\delta}{dt} + K_1 \Delta \delta$$

$$2\xi\omega_n = \frac{D_{PSS}}{2H}$$

And according to the two previous equations, the amount of K_c is obtained by the below equation:

$$4\xi\omega_n H = D_{PSS} = K_2 |G_c(4.72j)| |G_E(4.72j)| |G_c(4.72j)| = K_c \left| \frac{1 + T_1 4.72j}{1 + T_2 4.72j} \right|$$

$$|G_c(4.72j)| = K_c \left| \frac{1 + T_1 4.72j}{1 + T_2 4.72j} \right| = 21.3335$$

$$K_c = 8.46985$$

So the designed parameters for the PSS are in the table below:

$T_1=0.5296$	$K_c = 8.46985$
--------------	-----------------

Table 5: The designed parameters for the PSS

And the final block diagram for the system is as below :



Figure 7: The final PSS block diagram

4.3. The system modes after applying the PSS

$$\begin{bmatrix} \Delta \dot{\delta} \\ \Delta \dot{\omega} \\ \Delta \dot{E}_{FD} \\ \Delta \dot{E}'_q \\ \dot{u}_1 \\ \dot{u}_E \end{bmatrix} = \begin{bmatrix} 0 & \omega_b & 0 & 0 & 0 & 0 \\ -\frac{K1}{M} & 0 & 0 & -\frac{K2}{M} & 0 & 0 \\ \frac{K_5 K_a}{T_a} & 0 & -\frac{1}{T_a} & -\frac{K_a K_6}{T_a} & 0 & 0 \\ -\frac{K_4}{T_{do}} & 0 & \frac{1}{T_{do}} & -\frac{1}{T_{do} * K_3} & 0 & \frac{K_a}{T_a} \\ -\frac{K1}{M} & 0 & 0 & -\frac{K2}{M} & -\frac{1}{T} & 0 \\ -\frac{K_c K_1 T_1}{M T_2} & 0 & 0 & -\frac{K_c K_2 T_1}{M T_2} & \frac{K_c}{T_2} \left(1 - \frac{T_1}{T}\right) & -\frac{1}{T_2} \end{bmatrix} \begin{bmatrix} \Delta \delta \\ \Delta \omega \\ \Delta E_{FD} \\ \Delta E'_q \\ u_1 \\ u_E \end{bmatrix} \quad (24)$$

5. PSO

PSO is one of the methods among the many smart methods for solving the optimization problems, that was first introduced as an optimization method by Kennedy and Eberhart[12], and it is inspired by the birds wings. In the PSO algorithm, each particle has a value that is called fitness and it is calculated by the fitness function. This fitness is measured by the amount of the closeness to the target. Basically the beginning of the PSO is in a way that a group of particles are randomly created and in each level, each particle is optimized by the use of two optimum values.

The first value is called the best personal experience or the “pbest”. The other best result which is used is the best position that is gained by a group of particles and it is called the “gbest”.

The equation of the velocity updating:

$$v_i^{k+1} = v_i^k + c_1 rand_1 + (pbest_i - s_i^k) + c_2 rand_2 + (gbest_i - s_i^k) \quad (25)$$

The role of the weigh parameter in converging the algorithm is so important, because it is used for affecting the velocity at the present moment by the velocity of the previous moment.

The equation of the position updating:

$$s_i^{k+1} = s_i^k + v_i^{k+1} \quad (26)$$

Step 1) Assuming primary values for parameters like: congestion, the weigh function, the accelerator function and etc. The primary search (S_i^0) and V_i^0 are randomly selected for the N generating units. These primary particles are to create the possible solutions according to the possible operational limitations.

Step 2) Calculating the value of PGi core in the global particle

Step 3) Comparing the value of fitness for each particle, using its “pbest”. The best “pbest” is used as the “gbest”.

Step 4) V , the velocity of each particle according to the updating.

Step 5) the value of the position “s” is used as the changed position of each particle.

Step 6) if the value of the fitness is better than the value of “pbest”, the value of “pbest” is replaced by the present value of the function. Also, if the value of the “pbest” is better than the value of the present “gbest”, then it is replaced by its best amount and this best amount is stored.

Step 7) If the number of repetitions has reached to the preserved value, it goes to the step 8, otherwise it goes to the step 2.

Step 8) the particle that has generated the last “gbest”, is the most optimum generated power of each unit with the less total generation cost.

The steps mentioned above are shown in the flowchart below:

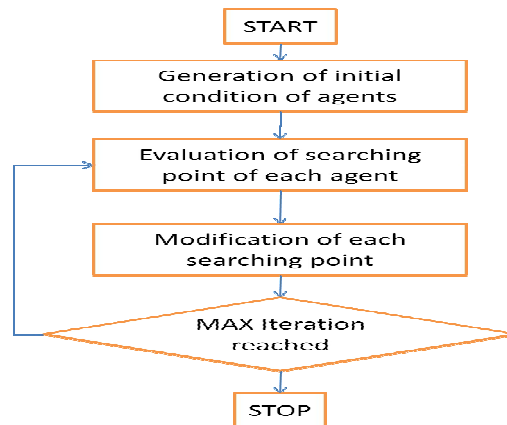

6. The Performance Index for the PSO

While examining the simulation, an error signal is used for checking the performance of the stabilizer of the power system and the coefficients that were used in it, and as shown in the figure. 6, it is obtained from the output of the angle variations and is given to the software as the index of improving the performance of the stabilizer system. This software prepares the best coefficients for gaining the best results. The position of each of the particles in each dimension, is bound to limitations that are defined by the user, and the primary velocities are bound to the range of $[V_{min}, V_{max}]$.

In this simulation, the goal is to minimize the amount of the error and the amount of the overshoot. For this reason, the target function is defined as the Integral Square Error (ISE). In this function, for eliminating the negative parts of the error, the square the error[13].

$$ISE = \int_0^{\tau} e^2(t) dt$$

6. Simulation

Figure 8 shows two diagrams, one of them is output of the system without the system stabilizer and the other one with the classic power system stabilizer system. The effect of stabilizer is obviously seen after happening of a turbulence in the waveform.

After that and in the figure 9, three diagrams are shown. Two of them, as mentioned in figure 8, are for the conditions that whether the stabilizer system is not used or the classic stabilizer is used. The 3rd diagram is the condition that the stabilizer system is utilized by the coefficients that are calculated and optimized by means of the smart PSO algorithm. As seen, calculating these values in an optimized way by means of this evolutionary algorithm, is a factor in improving the wave forms themselves, after happening of a turbulence.

The parameter of the PSS with PSO is:

T=20
Kc=47.7364
T1=0.1151
T2=1.0e-05

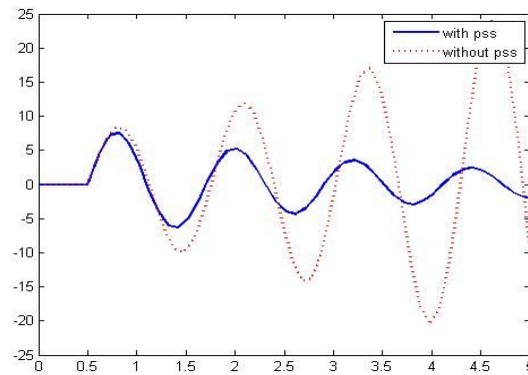
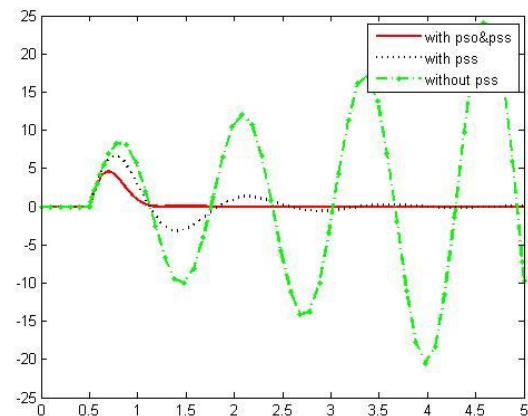
Table 6: The parameter of the PSO for PSS+**Figure 8: The Output of the system****Figure 9: The Output of the system**

The stabilization of a power system as one of the most complicated and sensitive dynamic systems, has always been under attention. The angle stabilization and the voltage stabilization are the two important aspects of the power system stabilization. In this research, the small signal concept was reviewed as some part of the angle stabilization concept. In the small signal issue, the goal is to raise the ability of the system to damping low frequency fluctuation(which are caused by small tubuzlences), so the system could be linearized about the work point. Because the target is to study the low frequency modes of the system, in the modeling of the machine, the fast modes that are caused by the stator dynamic are ignored.

Also by ignoring the dampers and stator resistances, the inherent attenuation of the system is ignored and this leads to conservatism in designing the stabilizer. So modeling the machine by the use of the linearized third degree model decreases the amount of complexity and also creates all of the preferred conditions. The single machine infinite bus model is the model that is used in this research.

7. Conclusion

Before using the stabilizer, the value of the damping torque is negative and this is caused by the AVR. So the studied system is an instable one. The instability of the system is calculated by means of the Eigen values analysis without the stabilizer, because the system has two mechanical modes in this state, both of which have positive values. So using the stabilizer is so important for this system.

After using the PSS, the degree of the system changes to 2 and two fast modes are added to the system that are caused by the control system. Also because the electrical and mechanical systems are not completely separate, then using the PSS affects the mechanical modes along with the electrical modes. At last it is seen that using the smart PSO algorithm leads to finding the most optimum coefficients for the stabilizer and as a result seeing the most optimum result with better attenuation.

In this research, a technic was used based on the particles swarm optimization for regulating parameters of a PSS constant structure. As the proposed controller system is stabilized, a minimum overshoot can be obtained and the limitations in the system are also satisfied.

The suggested algorithm is a compromise in finding the best answer, considering the overshoot and the physical limitations of the system.

References

- T. T. Nguyen, R. Gianto, " Neural networks for adaptive control coordination of PSSs and FACTS devices in multimachine power system", *IET Generation, Transmission and Distribution.*, vol. 2, no. 3, pp. 355–372, 2008.
- J. G. Vlachogiannis, K. Y. Lee, "Economic Load Dispatch-A Comparative Study On Heuristic Optimization Technique with an Improved Coordinated Aggregation-Based PSO" *IEEE Trans. Power Systems.*, Vol. 24, No.2, May 2009.
- C. Concordia, de Mello FP. "Concepts of synchronous machine stability as affected by excitation control." *IEEE Trans Power Appar Syst.*, 1969;PAS- 88(April):316–29.
- X .Ancheng, A .Pinghua , B .Tianshu "Global Governor-side Damping Controller for Low Frequency Oscillation of Power Systems Based on Partial State Feedback" ,*IEEE conference.*, 2010.
- Z. L. Gaing, "A particle swarm optimization approach for optimum design of PID controller in AVR system," *IEEE Trans. on Energy Conversion.*, vol. 19, no. 2, pp. 384-391, 2004.
- N. Hosseinzadeh, A. Kalam. "A rule-based fuzzy power system stabilizer tuned by a neural network." *IEEE Trans Energy Convers.*, 1999;14(3).
- H. F. Wang. "A Unified Model for the Analysis of FACTS Devices in Damping Power System Oscillations — Part III : Unified Power Flow Controller." *IEEE Transactions on Power Delivery.*, vol 15, no 3, July 2000, p 978.
- R. Hemmati, S. M. S. Boroujeni, E. Behzadipour, H. Delatkar, "Supplementary stabilizer design based on STATCOM," *India J.Sci.Technol.*, vol. 4, pp. 525-529, May 2011.
- G. Gurrala, I. Sen, "A Modified Heffron-phillip's Model for the Design of Power System Stabilizers," *Power system Technology and IEEE power India Conference.*, 2008.
- F. P. Demello, C. Concordia, "Concepts of synchronous machine stability as affected by excitation control," *IEEE Trans. Power Apparatus and Systems.*, vol. PAS-88, No.4, pp. 316–329, 1969.
- D. P. H. Krishna, B. N. S. P. Venkatesh, E. Ramesh, G. S. Sudheer "Design Of Power System Stabilizer To Improve Small Signal Stability By Using Modified Heffron-Phillip's Model.", *International Journal of Engineering Science and Technology (IJEST)*, Vol. 3 No. 6 June 2011.
- J. Kennedy, R. Eberhart. "Particle swarm optimisation." *In: Proceedings of the IEEE international conference of neural network (ICNN'95)*, vol. IV; 1995. p. 1942–8.
- J. H. Ahn, S. Choi, and J. H. Oh, "A new way of PCA: Integrated squared- error minimization," *IEEE Trans. Neural Networks*, 2003, submitted.